

# MANUAL

## TLS1 2.03



### IDENTIFICATION DATA OF THE MANUFACTURER

KOLVER S.r.l.  
VIA M. CORNER, 19/21  
36016 THIENE (VI) ITALIA

### IDENTIFICATION DATA OF THE PRODUCT

<b>MODEL:</b>	TLS1/CAR281	TLS1/CAR282	TLS1/CAR501	TLS1/CAR502	TLS1/LINAR1	TLS1/LINAR2	TLS1/LINART
<b>CODE:</b>	010663/TLS1	010664/TLS1	010665/TLS1	010666/TLS1	010681/TLS1	010682/TLS1	010683/TLS1

### TECHNICAL DATA OF THE PRODUCT

TENSIONE D'ALIMENTAZIONE: 12V DC  
DIMENSIONI: 170 x 100 x 35 mm PESO: 0,5 Kg

### DECLARATION OF CONFORMITY



**KOLVER S.r.l.** declare that this unit for TLS1 arm is in conformity with the following standards and other normative documents: 2006/42/CE, LVD 2014/35/UE, EMCD 2014/30/UE, EN 62841-2-2:2014, EN 62841-1: 2015, EN 60204-1, EN 61000-6-2, EN 61000-6-4.

.It is also in conformity with RoHS III normative (2011/65/UE and following 2015/863).

Name: Giovanni Colasante  
Position: General Manager  
Person authorized to compile the technical file in Kolver

Thiene, January 1st 2021

*Giovanni Colasante*

Code	Model	Max Torque	Dimensions mm		Min distance between screws at the max arm extension
			Min	Max	
010663/TLS1	TLS1/CAR281	25 Nm	500	950	9 mm
010664/TLS1	TLS1/CAR282	25 Nm	750	1670	15 mm
010665/TLS1	TLS1/CAR501	50 Nm	500	950	9 mm
010666/TLS1	TLS1/CAR502	50 Nm	750	1670	15 mm
010681/TLS1	TLS1/LINAR1	25 Nm	272	653	6 mm
010682/TLS1	TLS1/LINAR2	50 Nm	272	653	6 mm
010683/TLS1	TLS1/LINART	25 Nm	114	740	7 mm
To be connected to:					
260004/1	Cable TLS1 x EDU2AE + EDU2AE/TOP + EDU1BL/SG				
260003/1	Cable TLS1 x EDU1FR/SG				

Turn the unit on through the ON/OFF button on the front panel.

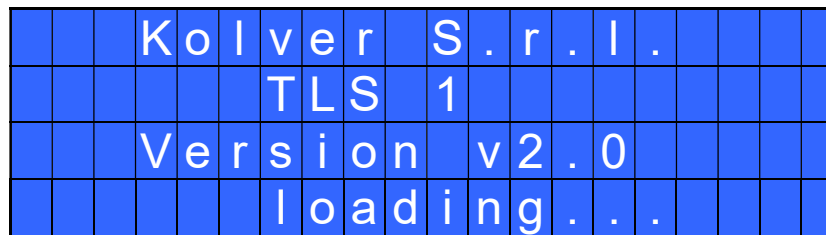

After about three secs, the system will automatically switch to the main screen (figure below).  
Main screen of CAR e LINAR1 models:

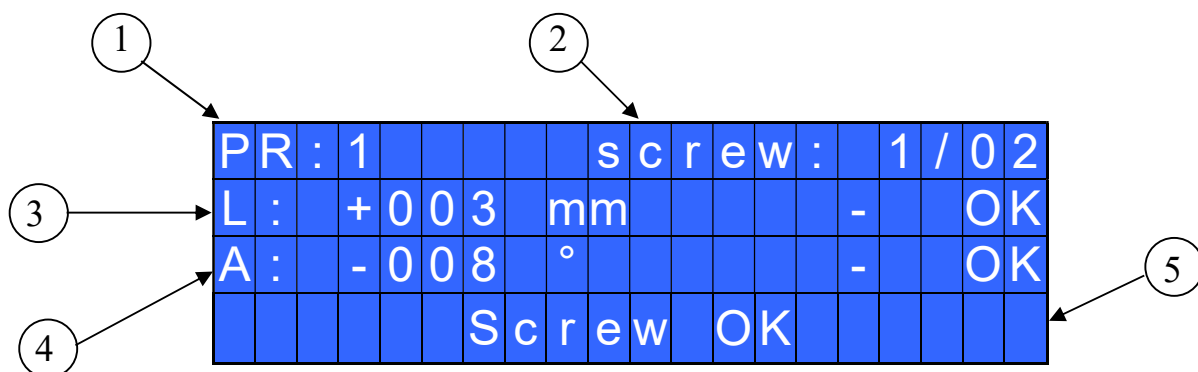

- 1- Program number
- 2- Screw count: fastened screws/total screws
- 3- Distance of the screwdriver from to screw (mm or in)
- 4- Distance in degrees of the screwdriver from to screw
- 5- Status bar (waiting, screwing, errors, etc...)





**OK GREEN LED:** the screwdriver is well positioned on the correct screw.

**NOK RED LED:** the screwdriver is positioned on a wrong screw.

**Screw OK GREEN LED:** the screwing/unscrewing has been done correctly. si è eseguita correttamente l'avvitatura/svitatura

**Cycle OK YELLOW LED:** the program has been achieved correctly.

**Screw NOK RED LED:** the screwing/unscrewing has

been done incorrectly.

## MAIN MENU

-	-	-	-	-	M	E	N	U	-	-	P	R	:	1	-	-	-	-	-
O	K		c	h	a	n	g	e			E	S	C		q	u	i	t	
→	P	r	o	g	r	a	m		s	e	t	t	i	n	g				
	O	p	t	i	o	n	s												

**Program Setting:** It indicates the menu section where you can set or modify the position of the screws.

**Options:** It indicates the menu section where you can set or modify the programs by remote, the password, the unit and the language.

## PROGRAM MENU

-	-	-	-	-	M	E	N	U	-	-	P	R	:	1	-	-	-	-	-
O	K		c	h	a	n	g	e			E	s	c		q	u	i	t	
→	1	)	P	r	o	g	r	a	m		n	u	m	b	e	r	:	1	
	2	)	S	e	t		p	o	s	i	t	i	o	n					

1) **Program number:** you can select the desired program from 1 to 8.

2) **Set position:** you can set the position of the screw (max 35 screws per program). Place the screwdriver on the screw and the position will be displayed. Press OK to save.

-	-	-	-	-	M	E	N	U	-	-	P	R	:	1	-	-	-	-	-
	3	)	P	r	o	g	r	a	m		i	n	f	o					
→	4	)	L	e	n	g	t	h		T	o	l	.	:	±	1	0		
	5	)	A	n	g	l	e		T	o	l	.	:	±	1	.	0		

3) **Program info:** to display the positions of the screws already saved (see point 2).

**4) Length Tol. (Length Tolerance):** you can set a tolerance value ( $\pm 1$  mm) of length measurement. This range can be set from 1 to 200 mm (resolution 1 mm). Press OK to confirm. The positions out of this range will result in a visual warning on the red led Position NOK. At the same time, to stop the motor, there will be an output signal to GND on pin2 of P1 connector.

In case of LINART, this parameter will be ANGLE1 and it will be the tolerance of the Angle1 (see point 5) referring to the Sensor.

**5) Angle Tol.:** you can set a tolerance value ( $\pm 0.5^\circ$ ) the measure of the angle. The range can be set from  $0.5^\circ$  to  $100.0^\circ$ . Press OK to confirm. The positions out of this range will result in a visual warning on the red led Position NOK. At the same time, to stop the motor, there will be an output signal to GND on pin2 of P1 connector.

In case of LINART, this parameter will be ANGLE2 and it will be the tolerance of the Sensor.

-	-	-	-	-	MENU	-	-	PR: 1	-	-	-	-
6	)	R	e	s	e	t	:					p r g
▶	7	)	P	r	e	s	s	OK:				o f f
8	)	P	r	e	s	s	ESC:					o f f

**6) Reset:** you can choose which parameter reset: the Program or the Screw. PRG = you reset the single Program. Screw = you reset the single screw.

**7) Press OK:** after a program end, if ON, the TLS1 unit resets automatically. If OFF, press OK every program end.

**8) Press ESC:** after an error signal, if ON, the TLS1 unit asks to press ESC to reset. If OFF, the TLS1 unit resets automatically.

## OPTIONS MENU

-	-	-	-	MENU	-	OPZIONI	-	-	-	-			
OK		c	h	a	n	g	e	ESC		q	u	i	t
▶	1	)	U	n	i	t		m	o	d	e	l	: K D U C E R
2	)	A	r	m		m	o	d	e	l	:		C A R

**1) Unit Model:** Select the unit connected to the TLS1 arm. Models available: Kducer and EDU.

**NB:** The K-ducer unit has PNP input signals, so it is suggested to mount an external 10 KOhm pull-up resistor between pin 1 and pin 2 of the P1 connector so that the stop motor can work correctly. In the specific cable for K-ducer (code 260004/KDU) the resistor is already mounted in the connector body.

- 2) Arm Model:** Select the arm model connected to the TLS1 arm. Models available: CAR, LINAR1 e LINART.
- 3) Select. progr:** Select the program from outside through the connector P3 (see I/O Connectors).
- 4) Change password:** You can modify the password.

-	-	-	-	M	E	N	U	-	O	P	T	I	O	N	S	-	-	-	-		
	3	)	S	e	l	e	c	t		p	r	o	g	r	:		o	f	f		
▶	4	)	C	h	a	n	g	e		p	a	s	s	w	o	r	d				
	5	)	P	a	s	s	w	o	r	d	:								o	f	f

- 1) **Password:** If ON, you will be asked for the password to enter the menu. Otherwise select OFF.  
ATTENTION: Password is only asked to enter the menu for the first time after switching the unit on. The default password is: 0000.
- 2) **Unit:** You can choose between the following units of the length measurements mm (millimeter) and in (inch).

-	-	-	-	M	E	N	U	-	O	P	T	I	O	N	S	-	-	-	-			
	6	)	U	n	i	t	:													m	m	
▶	7	)	L	a	n	g	u	a	g	e	:										E	N
	8	)	S	e	n	s	o	r		p	o	s	i	t	i	o	n					

- 3) **Language:** This option allows to choose among 6 languages: English, Italian, German, Spanish, French and Portuguese.
- 4) **Sensor position:** to see in real time on the display the position of the sensors.

## INTERPRETATION OF ACOUSTIC SIGNALS

The TLS1 unit emits sounds which help you understand if the screwing has been carried out correctly or not. When the torque is reached meeting all the parameters set, the TLS1 unit receives the signal from the EDU control unit connected and utters a 0.5 sec beep as confirmation. Other two beeps when the end of the program has been reached.

Instead in case of a wrong screwing, the TLS1 unit receives the error signal from the EDU control unit and you will hear three beeps.

## SETTING OF THE POSITION SENSOR (only LINAR arm)

After selecting the arm model you are going to use (Options Menu, point 1), you have to check the correct position of the sensor:

1. Enter in Options Menu, go to point 7 (Sensor Position)
2. Position the arm at its min extension.
3. On the main screen, check if the length (L) is 0mm
4. In case the value is different than 0, loosen the screws (see the picture below) and move horizontally the sensor until the value is 0.
5. Once found the correct position, tighten the screws previously losen and exit from the menu.

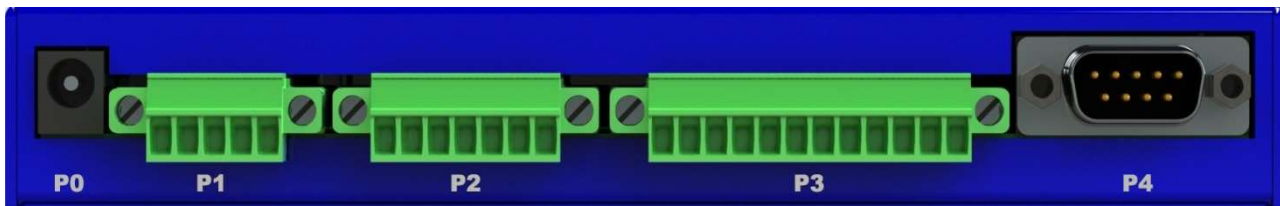
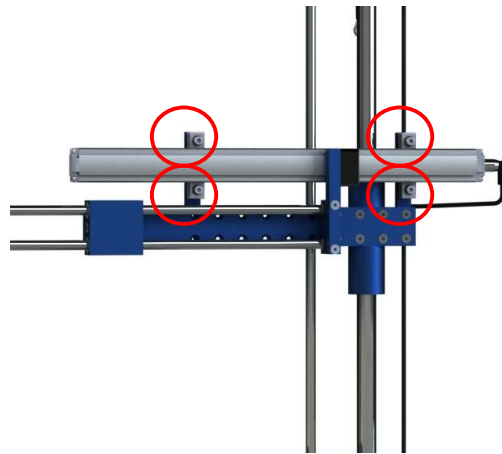

## I/O CONNECTIONS

- CONNETTORE P1 – 5 pin  
Connector to EDU2AE, EDU2AE/TOP or EDU1BL/SG control unit.

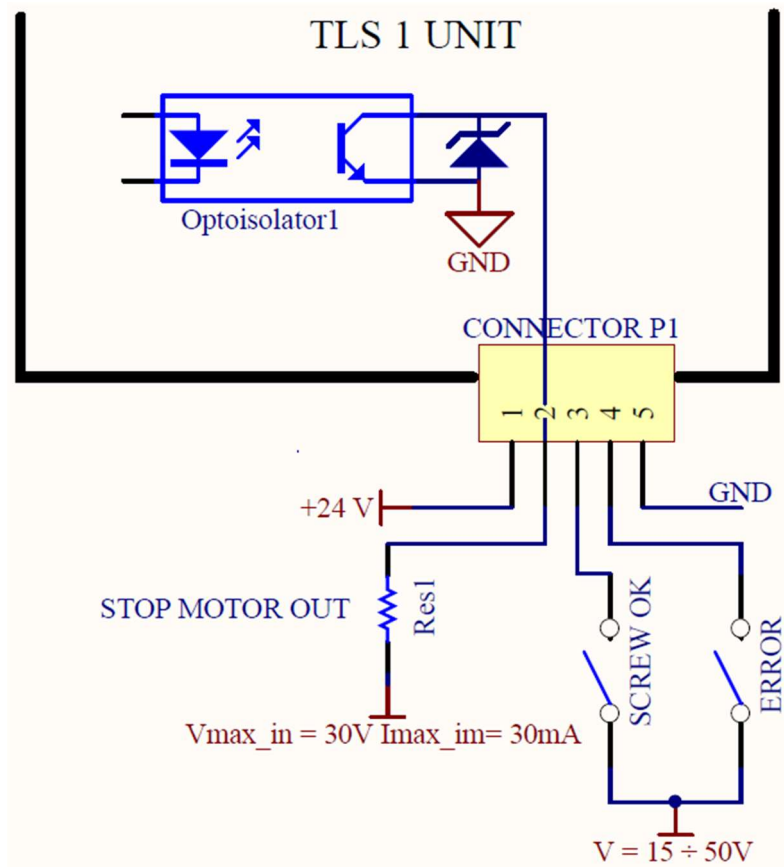

PIN	NAME	FUNCTION
1	+24V SIGNAL	INPUT: this pin gives TLS1 the right tension for leds and output signals. Using EDU2AE series and EDU1BL/SG units the power will be taken directly from the control unit via pin 1 of CN1. The maximum tension must be 24V 400mA.
2	STOP MOTOR OUT	OUTPUT: it is activated the arm is out of the pre-set tolerances. At the same time it activated the red led Position NOK on the front panel. When the signal is enabled, it creates a contact to GND.
3	SCREW OK	INPUT: NPN Screw OK signal. Whenever this signal is received by the TLS1, it increases by one the number of screws done. It also activates the Screw OK led.
4	ERROR	INPUT: NPN Error signal. It also activates the Screw NOK led.
5	COM0VDC	Common pin between the control unit and the TLS1. This pin is connected to 0VDC to the ground.

- CONNECTOR P2 – 7 pin:

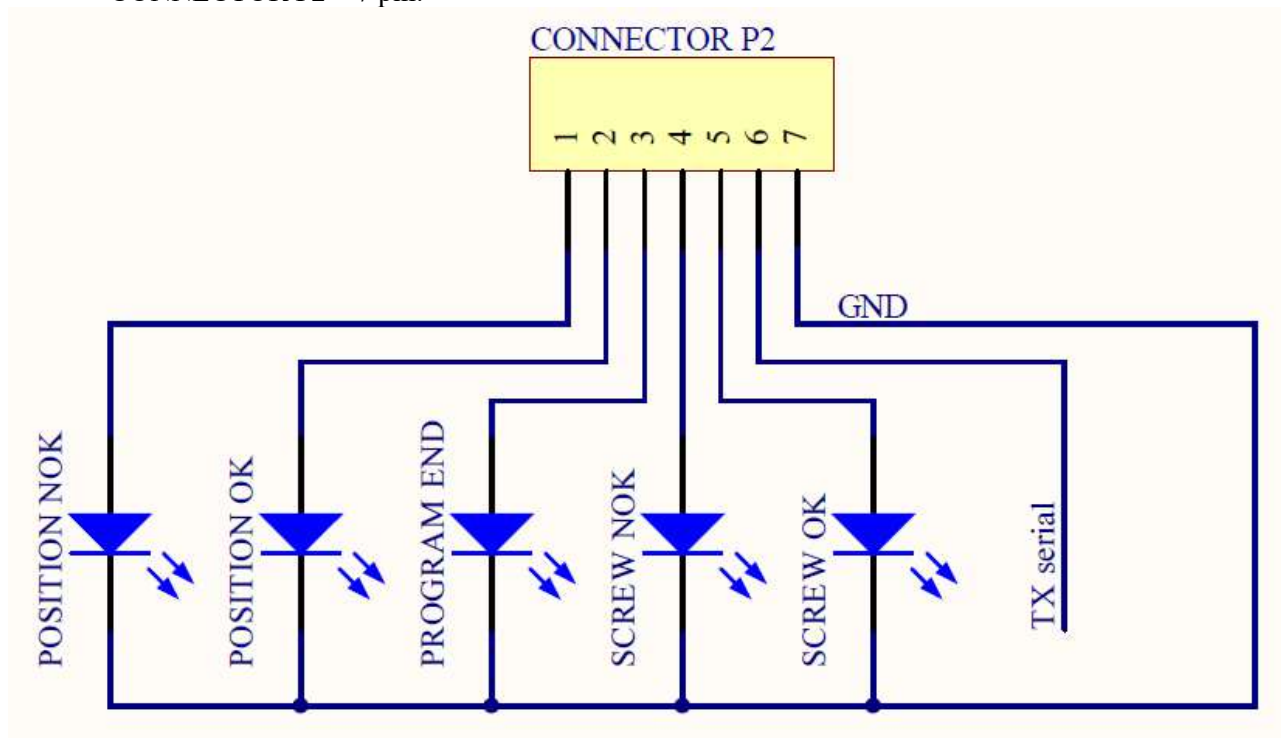

PIN	NAME	FUNCTION
<b>OUTPUT</b>		
1	POSITION NOK	The screwdriver is NOT placed on the correct screw. This means that at least one parameter is out of its tolerance. It activates the NOK red led.
2	POSITION OK	It shows that the screwdriver is placed on the correct screw. It activates the green OK led.
3	PROGRAM END	This signal works in parallel to the yellow Cycle OK led on the front panel. It indicates that the required number of screws in the program have been completed.
4	SCREW NOK	This signal works in parallel to the Screw NOK red led on the front panel. It indicates that unscrewing has been performed correctly.



5	SCREW OK	This signal works in parallel to the yellow led on the front panel. It indicates that a correct screwing has been performed.
6	Serial TX	Serial transmission.
7	COM0VDC	Common to every input (1-6). Signals have to be enabled making contact between the desired signal and this pin (common 0VDC).

**ATTENTION:** Output signals, if come from TLS1 unit, are protected from an appropriate circuit. Overload of the available signals (> 400 mA) or short circuit will result in the stop of the unit. To reactivate signals, it is necessary to switch off the unit for 5-6 seconds, check connections and output loads then switch the unit on.

- CONNECTOR P3

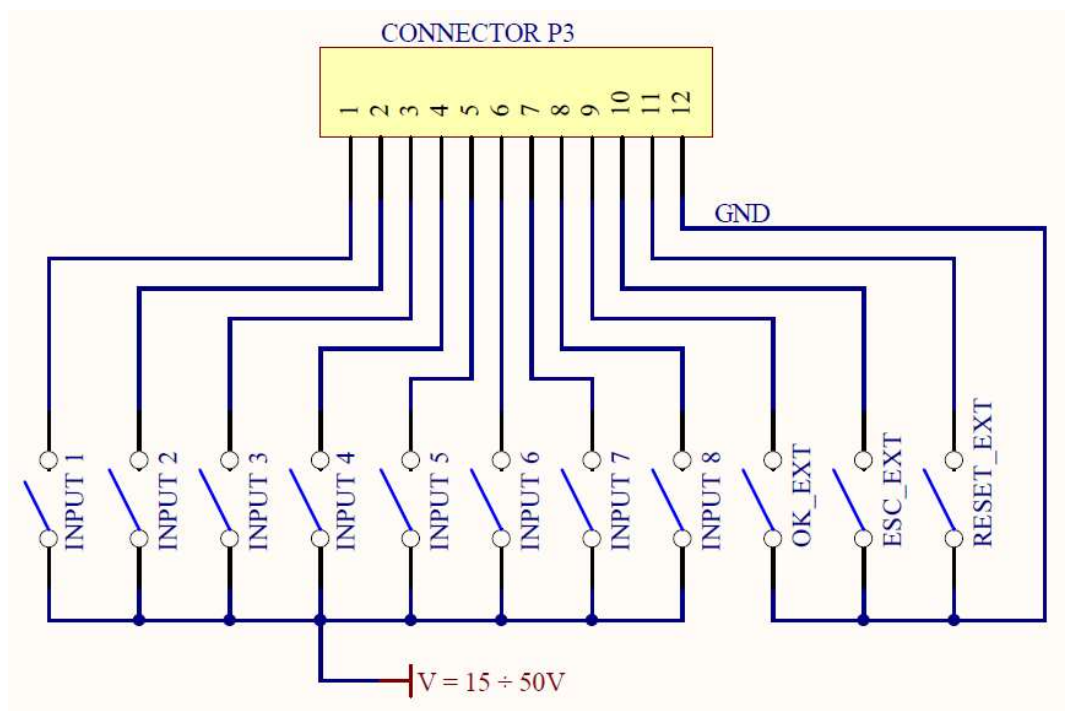

PIN	NAME	FUNCTION
<b>INPUT</b>		
1	INPUT 1	Pin to select the Program 1
2	INPUT 2	Pin to select the Program 2
3	INPUT 3	Pin to select the Program 3
4	INPUT 4	Pin to select the Program 4
5	INPUT 5	Pin to select the Program 5
6	INPUT 6	Pin to select the Program 6
7	INPUT 7	Pin to select the Program 7
8	INPUT 8	Pin to select the Program 8
9	OK	Remote OK key.
10	ESC	Remote ESC key.
11	RESET	Remote RESET key.
12	COM0VDC	Common to input 1-8: it is required +24 V between the respective pin of the desired signal of this connector and this pin (0V common). For input 9-10-11 it is required a contact to mass.

- CONNECTOR P4 (serial connector M 9 pin)

PIN	NAME	FUNCTION
1	SENSOR1	Reading of linear sensor1 (LINAR1 arm)
2	+12V	Pin for sensor1
6	SENSOR2	Reading of linear sensor2 or angular1 (CAR or LINART arms).
7	+5 V	Pin for sensor2 and 3.
8	SENSOR3	Reading of linear angular2 (CAR-LINAR1-LINART arms).
9	GND	Common pin for Positioning Arm sensors.

**IMPORTANT:** do not switch on the EDU2AE unit before the TLS1 unit. You should avoid that the unit reads the OK, ESC and RESET inputs (if they are set).

## SERIAL PRINT:

Every TLS 1 is supplied with a serial male 9 pin connector. You can print on PC (for example through Hyper Terminal programs) or printer (for example our printer PRNTR1) the results of each screw done.

The transmission characteristics are the following: 9600 (bits per second), 8 (data bits), n (no parity), 1 (bits stop 1). Connection P3: PIN 6 = TX, PIN 7 = GND.

The print string is the following:

RESULT	PROGRAM NUMBER	SCREW	NOTICE
--------	----------------	-------	--------

**Result** = screwing result: correct or incorrect.

OK = the screwing has been correctly performed. The control unit will give out a beep sound of 0.5 sec.

NOK = the screwing has NOT been correctly performed. In this case, the unit will give out 2 beep sounds and the red led will light up.

**PR: Program number** = it indicates the running program.

**Screw: Number of screws** = number of tightened screws/total number of screws.

**Notice** = in case of program end, it prints “Program End”, in case of sequence end, it prints “Seq. end” or it indicates the type of error (see paragraph: trouble shooting).

Example of serial print:

```

OK PR:1 Screws: 1/4
OK PR:1 Screws: 2/4
NOK PR:1 Screws: 2/4
NOK PR:1 Screws: 2/4
OK PR:1 Screws: 3/4
OK PR:1 Screws: 4/4 Prog_end
OK PR:1 Screws: 1/4

```

1) screw OK

2) screw NOK

# EXPLODED VIEW

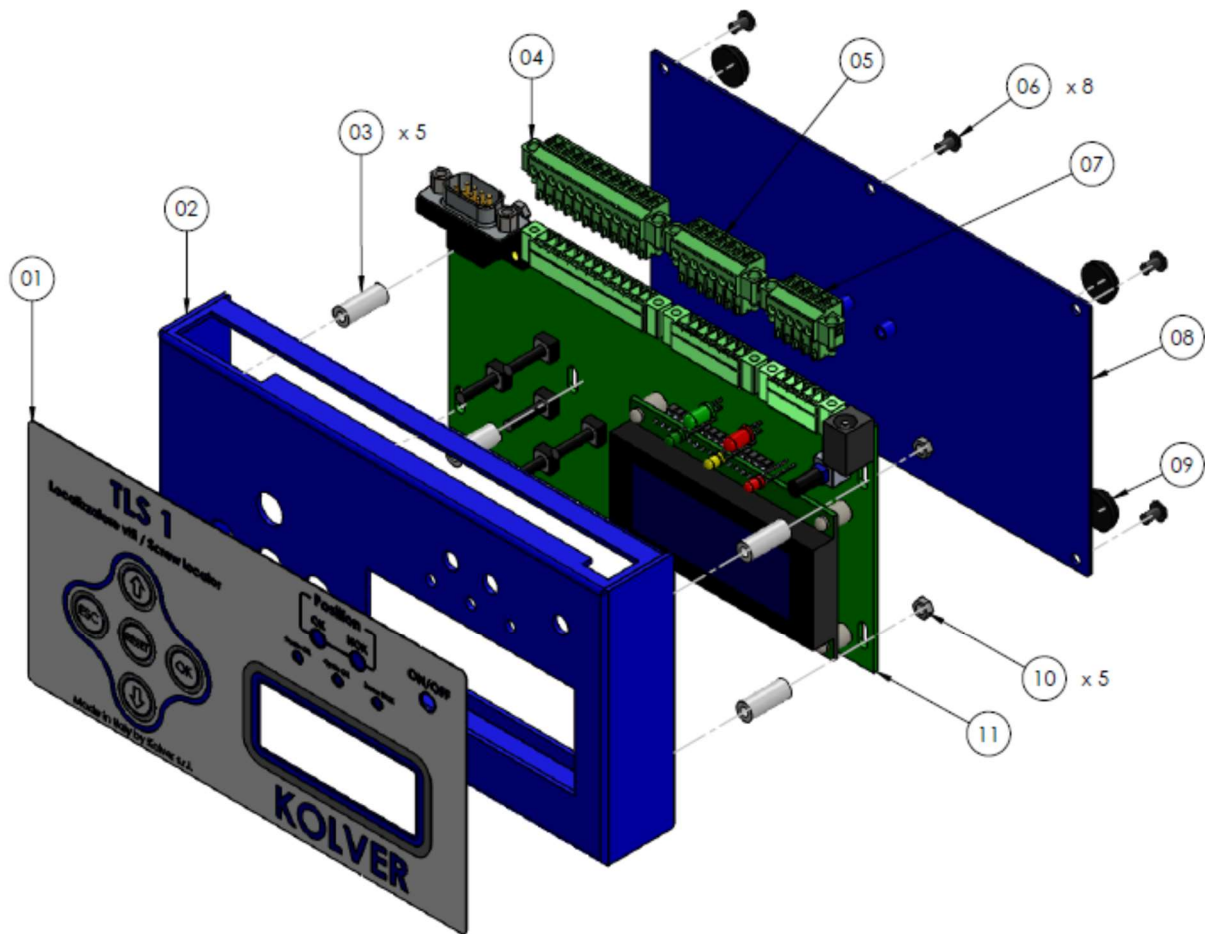

## SPARE PARTS

Position	Description	Quantity	Code
1	Membrane TLS 1	1	896001
2	Upper panel TLS 1	1	896002
3	Spacer 15mm dest4.8mm	5	890004/T
4	Connector 12 poli spacing 3,50 – F	1	890009
5	Connector F 7 pin spacing 3,50 – F	1	891030
6	Screw 3x5	8	872443
7	Connector I/O 5 pin spacing 3,50 – F	1	891029
8	Base TLS1	1	896003
9	Plastic support	4	800016
10	Nut M3 zn-white	5	800056
11	Main board TLS 1	1	896000
	Power supply 12V	1	241009/N

## GUARANTEE

1. This KOLVER product is guaranteed against defective workmanship or materials, for a maximum period of 12 months following the date of purchase from KOLVER, provided that its usage is limited to single shift operation throughout that period. If the usage rate exceeds of single shift operation, the guarantee period shall be reduced on a prorata basis.
2. If, during the guarantee period, the product appears to be defective in workmanship or materials, it should be returned to KOLVER or its distributors, transport prepaied, together with a short description of the alleged defect. KOLVER shall, at its sole discretion, arrange to repair or replace free of charge such items.
3. This guarantee does not cover repair or replacement required as a consequence of products which have been abused, misused or modified, or which have been repaired using not original KOLVER spare parts or by not authorized service personnel.
4. KOLVER accepts no claim for labour or other expenditure made upon defective products.
5. Any direct, incidental or consequential damages whatsoever arising from any defect are expressly excluded.
6. This guarantee replaces all other guarantees, or conditions, expressed or implied, regarding the quality, the marketability or the fitness for any particular purpose.
7. No one, whether an agent, servant or employee of KOLVER, is authorized to add to or modify the terms of this limited guarantee in any way. However it's possible to extend the warranty with an extra cost. Further information at [kolver@kolver.it](mailto:kolver@kolver.it).