

Operational Manual

EDU2AE/FR 2.00

Torque range: 0.2-50 Nm



IDENTIFICATION DATA OF THE MANUFACTURER

KOLVER S.r.l.
VIA M. CORNER, 19/21
36016 THIENE (VI) ITALIA

IDENTIFICATION DATA OF THE PRODUCT

| | |
|---------------|------------|
| MODEL: | EDU 2AE/FR |
| CODE: | 032000/FR |

TECHNICAL DATA OF THE PRODUCT

FUSE: 3.15 A
DIMENSIONS: 195 x 170 x h110 mm WEIGHT: 2,4 Kg

DECLARATION OF CONFORMITY



KOLVER S.r.l. declares that the new tool here described: control unit model EDU 2AE/FR is in conformity with the following standards and other normative documents: 2006/42/CE, LVD 2014/35/UE, EMCD 2014/30/UE, EN 60745-1, EN 60204-1, EN 61000-6-2, EN 61000-6-3.
It is also in conformity with RoHS II normative (2011/65/UE).

Name: Giovanni Colasante
Position: General Manager
Person authorized to compile the technical file in Kolver.

Thiene, January 1st 2017

Giovanni Colasante

EDU 2AE/FR power supply and control unit is an innovative system for controlling the torque of any clutch model of PLUTO clutch series: PLUTO 3FR, PLUTO 5FR and PLUTO 7FR. Of FAB series: FAB03, FAB10, FAB12 and FAB18. And of RAF series: RAF32, RAF38 and RAF50. They are available either inline, pistol, for automation and with angle head (only PLUTO).

EDU 2AE/FR delivers all the advantages of precision torque control electric tools at a fraction of the price of transdurized tools.

The state-of-the-art electronic control circuit cuts the power supply to the motor calculating the correct torque in response to 3 parameters; voltage, frequency and current, according to the selected options.

The AC 90÷260V - 50÷60Hz power supply is converted into 40VDC required by the PLUTO series screwdrivers through a switching board.

| Model | Torque (Nm) | Speed (rpm) | |
|-----------|-------------|-------------|------|
| | | Min | Max |
| PLUTO 3FR | 0,5 - 3,2 | 800 | 1300 |
| PLUTO 5FR | 0,7 - 5 | 600 | 1000 |
| PLUTO 7FR | 1,5 - 7 | 350 | 600 |
| FAB03 | 0,05 - 0,3 | 450 | 650 |
| FAB10 | 0,05 - 0,8 | 600 | 1000 |
| FAB12 | 0,2 - 1,2 | 600 | 1000 |
| FAB18 | 0,3 - 1,8 | 450 | 650 |
| RAF32 | 0,7 - 3,2 | 600 | 1000 |
| RAF38 | 0,9 - 3,8 | 450 | 650 |
| RAF50 | 0,9 - 5 | 400 | 700 |

Turn the unit on through the on/off switch on the back panel. The unit will carry a general system check and “*waiting connection*” will appear on the last line of the display. If the connection with the motor control board is successful the following screen will be displayed:

| | | | | | | | | | | | | | | | | | |
|---|---|---|---|---|---|---|---|---|---|---|---|---|---|---|---|---|---|
| K | o | l | v | e | r | S | . | r | . | l | . | | | | | | |
| | | | | E | D | U | | 2 | A | E | / | F | R | | | | |
| | | | | V | e | r | s | i | o | n | | 2 | . | 0 | 0 | | |
| | | | | | | | | l | o | a | d | i | n | g | . | . | . |

Press any key on the front panel to enter the main screen (see following picture).

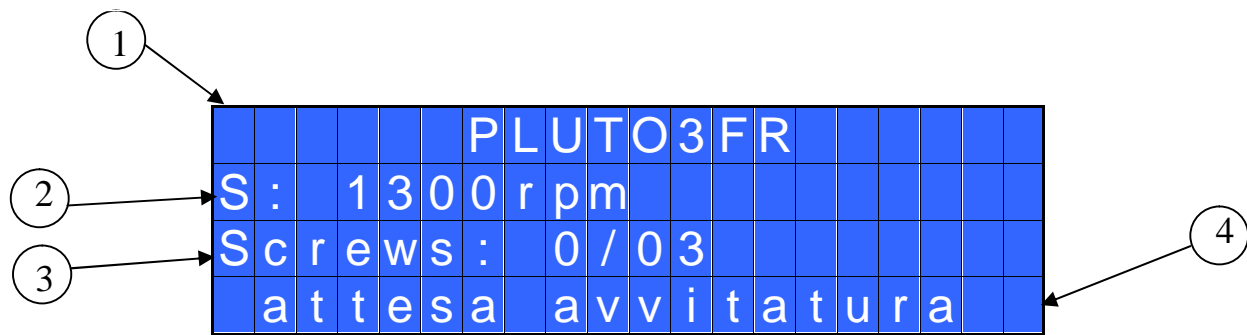

- 1- Screwdriver model
- 2- Selected speed
- 3- Screw count: fastened screws/total screws
- 4- Status bar (waiting, screwing, errors, etc...)



To enter the menu press **ESC** for 2 seconds.

Select the line by pressing **↑** or **↓** then press **OK** (the symbol **▶** will turn into **■**). Press **↑** or **↓** to select the required value and then confirm through **OK** (or **ESC** if you don't want to save the value).

The selected value will be immediately operational, even if you are still in the menu screen. Repeat these operations for all the parameters you wish to set and then push **ESC** to return to the main screen.

FRONT PANEL LED:



GREEN LED: *Screw OK.*

YELLOW LED: *Program End (only on EDU 2AE/HPro).*

RED LED: error.

MENU

| | | | | | | | | | | | | | | | | | | | |
|---|---|---|---|---|---|---|---|---|---|---|---|---|---|---|---|---|---|---|---|
| - | - | - | - | - | M | A | I | N | - | M | E | N | U | - | - | - | - | - | - |
| O | K | | c | h | a | n | g | e | | | E | S | C | | q | u | i | t | |
| ▶ | P | r | o | g | r | a | m | | s | e | t | t | i | n | g | | | | |
| | U | n | i | t | | o | p | t | i | o | n | s | | | | | | | |

Program setting: It indicates the menu section where you can set or modify the fastening parameters.

Unit Options: It indicates the menu section where you can set the language, the password and the unit.

Program setting

| | | | | | | | | | | | | | | | | | | | |
|---|---|---|---|---|---|---|---|---|---|---|---|---|---|---|---|---|---|---|---|
| - | - | - | - | - | - | - | - | M | E | N | U | - | - | - | - | - | - | - | - |
| O | K | | c | h | a | n | g | e | | | E | S | C | | q | u | i | t | |
| ▶ | 1 |) | M | o | d | e | l | : | | | P | L | U | T | O | 3 | F | R | |
| | 2 |) | R | a | m | p | : | | | | | | | | 0 | . | 3 | s | |

1) Model: you can select the screwdriver to be used. Your choice will automatically change the default settings. It's important to select the correct model you're going to use since many parameters regarding the motor software are specific for every single model.

2) Ramp: You can select the slow start time (acceleration) from 0.2 to 3.0 sec. This option is only available for the screwing phase, while during the unscrewing phase the ramp time is always 0.2 sec. We suggest using this option with self tapping screws.

ATTENTION: Reaching the torque while the ramp is still on will activate the "screw OK" signal anyway (this option is useful if you need to tighten screws that are already tightened, the so called "double hit"). On the other hand, if you wish to see an error signal during the preset torque in the ramp phase, you can change the minimum time by setting value which is equal or superior to the ramp value (see point 8).

| | | | | | | | | | | | | | | | | | | | |
|---|---|---|---|---|---|---|---|---|---|---|---|---|---|---|---|---|---|---|---|
| - | - | - | - | - | - | - | - | M | E | N | U | - | - | - | - | - | - | - | - |
| | 3 |) | F | i | n | a | l | | S | p | d | : | 1 | 3 | 0 | 0 | r | p | m |
| ▶ | 4 |) | R | u | n | | t | i | m | e | : | | | | | | o | f | f |
| | 5 |) | M | i | n | | t | i | m | e | : | | | | | | o | f | f |

3) Final Spd (Final Speed): You can select any speed value of the screwdriver between the maximum and the minimum specific speed of every single screwdriver (see table with technical data).

4) Run time: You can set the time of a tightening, from OFF to 20.0 sec. When the pre-set time has been reached, it results in a torque signal.

The couple reached during this time results in a signal of *Correct screw*. If the correct screw signal is not required, set the Minimum time up to a value of 'Minimum Time -0.1sec'.

ATTENTION: Max Time must be set at 20.0 sec.

5) Min Time - Minimum Time: You can set this time from 0.1 sec to 'Max time - 0.1s'. To disable the function select OFF by pressing \downarrow as many times as needed. (Min time = 0). Torque reached below the minimum time won't activate the torque signal and will result in an error signal. "Below minimum time" will be displayed on the status bar and the red led will light up. You will hear two beep sounds, too.

| | | | | | | | | | | | | | | | | | | | | |
|---|---|---|---|---|---|---|---|---|---|---|---|---|---|---|---|---|---|---|---|---|
| - | - | - | - | - | - | - | - | M | E | N | U | - | - | - | - | - | - | | | |
| 6 |) | M | a | x | | t | i | m | e | : | | | | 2 | 0 | . | 0 | S | | |
| ▶ | 7 |) | A | u | t | o | | r | e | v | : | | | | | | o | f | f | |
| | 8 |) | M | i | n | | t | i | m | e | : | | | | | | | o | f | f |

6) Max time - Maximum time: You can select the maximum time of tightening. You can set from 'Min time + 0.1s' to 20.0 sec.

You also can set the Maximum time to OFF by pressing the \uparrow button when you have reached the value of 20.0s. In this case the screwdriver turns without any time limit.

ATTENTION: If torque isn't reached by the maximum time, the screwdriver will stop. "Over maximum time" will be displayed on the status bar and the red led will light up. You will hear two beep sounds, too.

7) Auto Rev: This option will automatically start a reverse after a torque reached/ correct screw signal. You can set time from 0.1 to 20.0 sec.

To disable the function select OFF by pressing \downarrow as many times as needed.

ATTENTION: During the reverse, it is necessary to keep the lever or the start signal pressed as long as it won't stop. "Correct screw" will be displayed on the status bar and a green led will light up. You will hear one beep sound, too. In case the lever is released before the end of the reverse, "unfinished screw" will be displayed and a red led will light up. You will hear two beep sounds, too.

8) Screws number: The EDU2AE/FR can act as screw counter. You can set the number of screws from 1 to 99. To disable the function select OFF by pressing \downarrow as many times as needed.

If the number of correct screws is equal to the number of set screws "Program end" will appear on the status bar and the yellow led will light up. If the *Press OK* function is disabled, "Program end" will automatically disappear at next screwing or when you enter the menu. Otherwise, press OK at the end of each program.

ATTENTION: Every time you enter the menu, the number of screws resets to zero.

Unit Options

| | | | | | | | | | | | | | | | | | | | |
|----|---|---|---|---|---|---|---|---|---|---|---|---|---|---|---|---|---|---|---|
| - | - | - | - | O | P | T | I | O | N | S | - | M | E | N | U | - | - | - | - |
| OK | | c | h | a | n | g | e | | | | E | S | C | | q | u | i | t | |
| ▶ | 1 |) | L | a | n | g | u | a | g | e | : | | | | | | | E | N |
| | 2 |) | V | e | r | s | i | o | n | s | | | | | | | | | |

1) Language: This option allows to select among 4 languages: English, French, German, Italian, Spanish and Portuguese.

2) Versions: in this screen you can see the versions of boards inside the unit.

| | | | | | | | | | | | | | | | | | | | |
|---|---|---|---|---|---|---|---|---|---|---|---|---|---|---|---|---|---|---|---|
| - | - | - | - | O | P | T | I | O | N | S | - | M | E | N | U | - | - | - | - |
| 3 |) | C | y | c | l | e | s | : | 0 | 0 | 0 | 0 | 0 | 0 | 0 | 0 | 0 | 0 | 0 |
| ▶ | 4 |) | C | h | a | n | g | e | p | a | s | s | w | o | r | d | | | |
| 5 |) | P | a | s | s | w | o | r | d | | | | | | | | | | |

3) Cycles - Number of total screwing/errors done which have been carried out: It shows the number of fastened screws and occurred errors. This number can't be modified.

4) Change password: You can change password (see point 5).

5) Password: If YES, you will be asked for the password to enter the menu. Otherwise select NO.

ATTENTION: Password is only asked to enter the menu for the first time after switching the unit on. The default password is: 0000.

| | | | | | | | | | | | | | | | | | | | |
|---|---|---|---|---|---|---|---|---|---|---|---|---|---|---|---|---|---|---|---|
| - | - | - | - | O | P | T | I | O | N | S | - | M | E | N | U | - | - | - | - |
| 6 |) | P | r | e | s | s | | O | K | : | | | | | o | f | f | | |
| ▶ | 7 |) | P | r | e | s | s | | E | S | C | : | | | o | f | f | | |
| | | | | | | | | | | | | | | | | | | | |

6) Press OK: when ON, press OK at the end of each screwing. When OFF, the control unit resets automatically after a screwing.

7) Press ESC: when ON, press ESC to reset the control unit. When OFF, the control unit resets automatically after an error signal.

INTERPRETATION OF ACOUSTIC SIGNALS

The control unit emits sounds which help you understand if the screwing has been carried out correctly or not. When the torque is reached meeting all the parameters set, the control unit utters a 0.5 sec beep as confirmation. In case of Program End, the unit will utter other two beeps. Instead, torque reached under min time, during the Ramp time or under the Fast speed (see error signals on the display) will cause the control unit to utter three beep sounds.

I/O CONNECTIONS

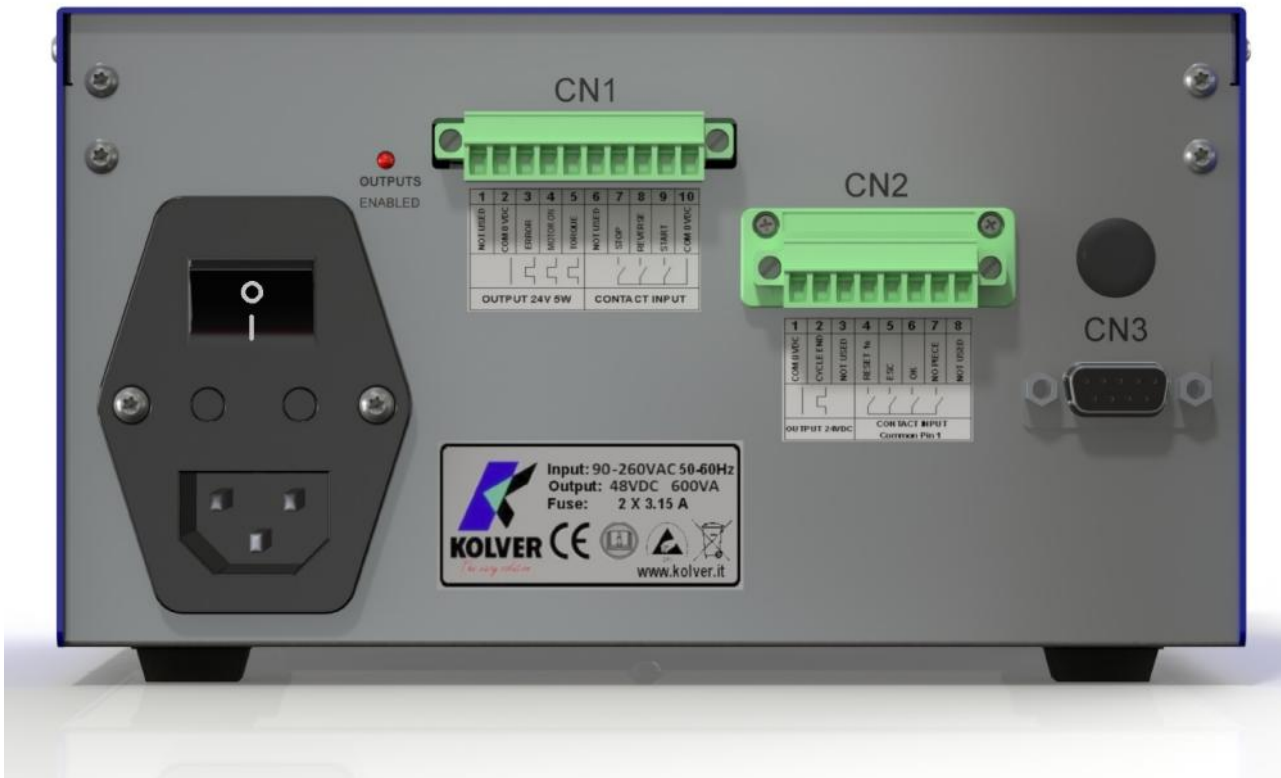

- CN1 CONNECTOR – 10 pin:
 On the back panel, in all the EDU 2AE units, there is a 10 pin I/O connector.

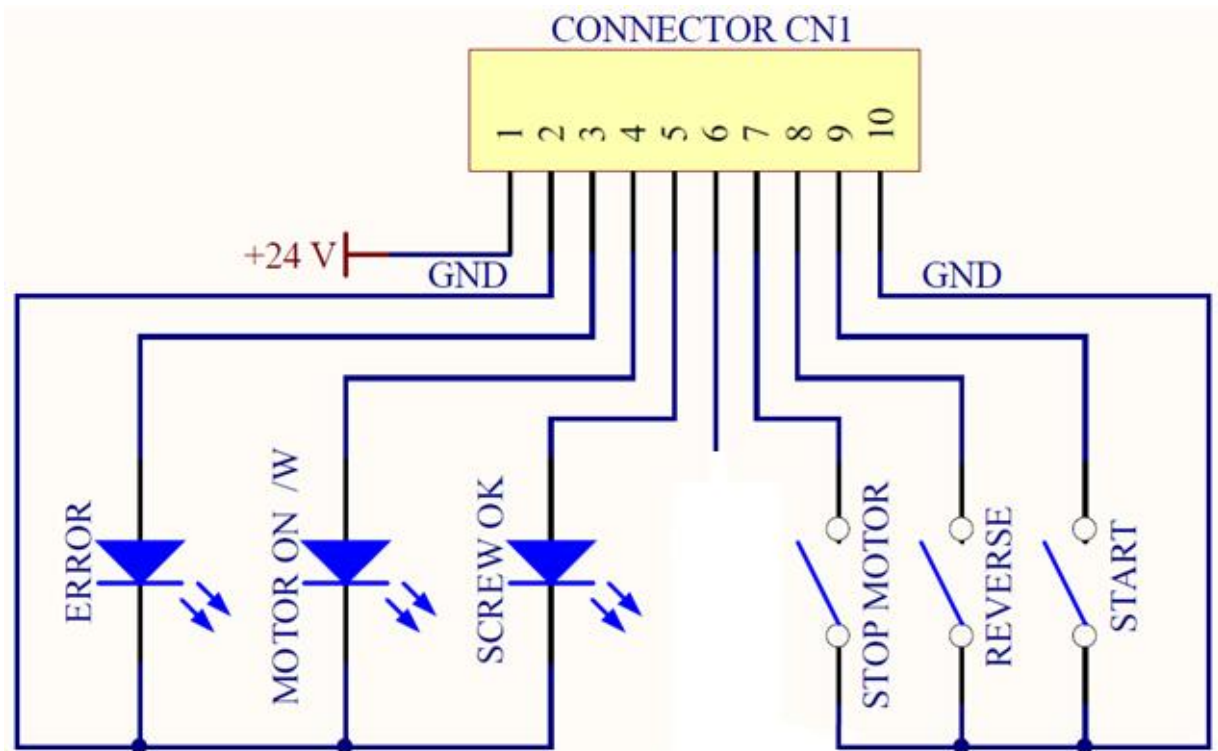

| PIN | NAME | FUNCTION |
|---------------|--------------|--|
| OUTPUT | | |
| 1 | +24V | +24V voltage protected. The maximum current consumption is 400mA. CAN NOT BE USED TO POWER EXTERNAL DEVICES. |
| 2 | GND | Common pin. Signals must be taken between this pin (GND) and the respective signal pins. |
| 3 | ERROR | Error signal: it activates every time an error occurs. The red led on the front panel will switch on. Signal is 24V. |
| 4 | MOTOR ON (W) | It activates when the motor turns during screwing. Signal is 24V. |
| 5 | SCREW OK | Correct screw signal. The green led on the front panel will switch on. Signal is 24V. |
| INPUT | | |
| 6 | NOT USED | Not used |
| 7 | STOP MOTOR | Remote motor stop. If it's activated the message "STOP MOTOR ON" appears on the display. The motor will stop and won't start working again as long as the contact is closed. |
| 8 | REVERSE | Remote motor start with torque control while unscrewing. |
| 9 | START | Remote start with torque control while screwing. |
| 10 | GND | Common pin. Signals must be taken between this pin and the respective signal pins. |

- CN2 CONNECTOR – 8 pin:

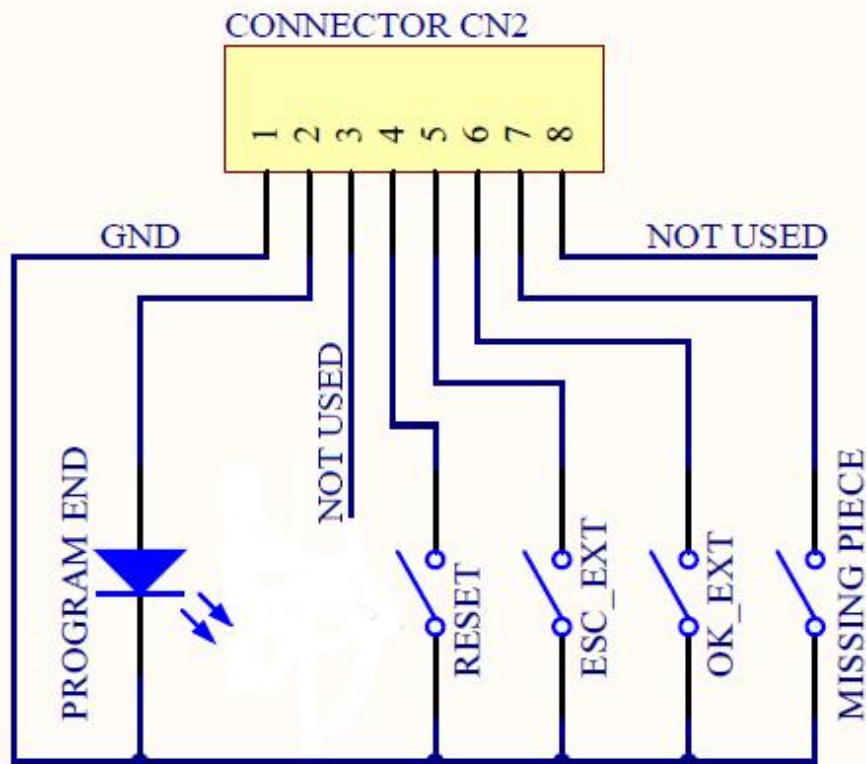

| PIN | NAME | FUNCTION |
|---------------|---------------|---|
| OUTPUT | | |
| 1 | GND | Common pin for any input and output. By closing the contact between pin 1 and any of the other pins to start the function you need. |
| 2 | PROGRAM END | It activates at the end of each program. |
| 3 | | Not used. |
| INPUT | | |
| 4 | RESET | If pressed for at least 1 sec, it resets the program you are working in. |
| 5 | ESC_EXT | If enabled, (see point 8: Press ESC), remote ESC key function to reset errors. |
| 6 | OK_EXT | If enabled, (see point 7: Press OK), remote OK key function to confirm program end. |
| 7 | MISSING PIECE | If enabled, it stops the motor, it enables the error signal and "Error missing piece" is displayed on the status bar. |
| 8 | | Not used. |

ATTENTION: Output signals are protected from an appropriate circuit. Overload of the available signals (> 450 mA) or short circuit will result in the stop of the unit. To re-activate signals, it is necessary to switch off the unit for 5-6 seconds, check connections and output loads then switch the unit on.

- CN3 CONNECTOR (9 pin serial connector – female)

| PIN | NAME | FUNCTION |
|-----|---------|---|
| 1 | +15 Vcc | Not used. |
| 2 | TX | Serial transmission. |
| 5 | GND | Common pin for any input. Signals must be taken between this pin (GND) and the other pins of this connector depending on the signal you want to be printed. |

CORRECT SCREWS ON STATUS BAR

| | |
|---|---|
| "Screw OK" is displayed on the status bar. | The tool has performed a correct screwing, that is when all the settings have been fulfilled. |
| "Run Time OK" is displayed on the status bar. | The tool has performed a correct screwing, that is when all the settings have been fulfilled. |

TROUBLE SHOOTING

| ERROR | PROBLEM | SOLUTION |
|-------|--|--|
| 0 | “waiting connection” doesn’t turn into “system ready” after it’s been switched on. | Contact your nearest Kolver dealer. |
| 2 | “ <i>Rev. incomplete</i> ” is displayed on the status bar (the displayed torque signal is correct but the set unscrewing is not complete). | If <i>Press ESC</i> function is ON, press ESC for a new screw; if it’s OFF it automatically resets next time you screw. |
| 3 | “ <i>Under min time</i> ” is displayed on the status bar (the torque signal is displayed below the set minimum time). | |
| 4 | “ <i>Over maximum time</i> ” is displayed on the status bar (the torque signal is displayed over the set maximum time). | |
| 11 | “Error unscrew torque” is displayed on the status bar (The torque signal is displayed while unscrewing, but only if it’s set on “max”). | <ul style="list-style-type: none"> - The screwdriver couldn’t unscrew. - Avoid motor stalling. - Unscrewing too heavy. |
| 12 | “Protection 12A” is displayed on the status bar (it happens when current on mosfets of bridge H is > 12 A for at least 1 sec). | <ul style="list-style-type: none"> - Reduce cycle rate and check settings. - Avoid motor stalling. - Unscrewing too heavy. - Joint too soft. |
| 13 | “ <i>Protection 14p5A</i> ” is displayed on the status bar (it happens when current on mosfets of bridge H is > 14.5 A for at least 800 ms). | <ul style="list-style-type: none"> - Reduce cycle rate and check settings. - Avoid motor stalling. - Unscrewing too heavy. - Joint too soft. |
| 14 | “ <i>Protection 15A</i> ” is displayed on the status bar (it happens when current on mosfets of bridge H is > 15 A for at least 500 ms). | <ul style="list-style-type: none"> - Reduce cycle rate and check settings. - Avoid motor stalling. - Unscrewing too heavy. |
| 15 | “OUTPUT DISABLED” is displayed on the status bar. It is on the protection of the output signals exceeding the maximum load (400mA). | <ul style="list-style-type: none"> - Check that the load does not exceed the max (400mA) - To reset, restart the unit. |

ATTENTION: IF THE OK/ESC OPTION IS DISABLED, ERRORS RESET AT THE FOLLOWING SCREWING/PROGRAM. OTHERWISE PRESS ESC. IF THE PROBLEM PERSISTS, PLEASE CONTACT YOUR NEAREST KOLVER DEALER.

SERIAL PORT only on EDU 2AE/FR:

EDU 2AE/FR control unit is supplied with a serial 9 pin male connector. In this way you can print the results of each screwing. The transmission characteristics are the following:

9600 (bits per second), 8 (data bits), n (no parity), 1 (bits stop 1).

Connection pin: PIN 2 = TX, PIN 5 = GND

The print string is the following:

| RESULT | SCREWDRIVER MODEL | SPEED | SCREW COUNT | NOTICE |
|--------|----------------------|-------|----------------|--------|
|--------|----------------------|-------|----------------|--------|

Result = screw evaluation: correct or incorrect.

OK = the torque has been correctly reached, all the selected parameters are satisfied and the control unit will give out a beep sound of 0.5 sec.

NOK = the torque has been reached during the ramp time or the fast speed (see error table). In this case, the unit will give out 2 beep sounds and the red led will light up.

Screwdriver model = model of selected screwdriver.

S: Speed = speed value.

Screws: Count = number of screws screwed/number of total screws of the sequence/ program.

Notice = in case of program end, it prints "Program End" or it indicates the type of error (see paragraph: trouble shooting).

Example of serial print:

```

OK  PLUTO10  T%:20% S: 600rpm ST: 0.8s Screw:01/03 T: 3.00 Nm
OK  PLUTO10  T%:20% S: 600rpm ST: 0.8s Screw:02/03 T: 3.01 Nm
OK  PLUTO10  T%:20% S: 600rpm ST: 0.1s Screw:03/03 T: 3.04 Nm Program end
NOK PLUTO10  T%:20% S: 600rpm ST: 6.0s Screw:00/03 T:--,-- Error max time
OK  PLUTO10  T%:20% S: 600rpm ST: 1.1s Screw:01/03 T: 3.04 Nm
NOK PLUTO10  T%:20% S: 600rpm ST: 6.0s Screw:01/03 T:--,-- Error max time
OK  PLUTO10  T%:20% S: 600rpm ST: 1.4s Screw:02/03 T: 3.00 Nm
OK  PLUTO10  T%:20% S: 600rpm ST: 1.5s Screw:03/03 T: 3.00 Nm Program end

```

EXPLODED VIEW EDU2AE/FR

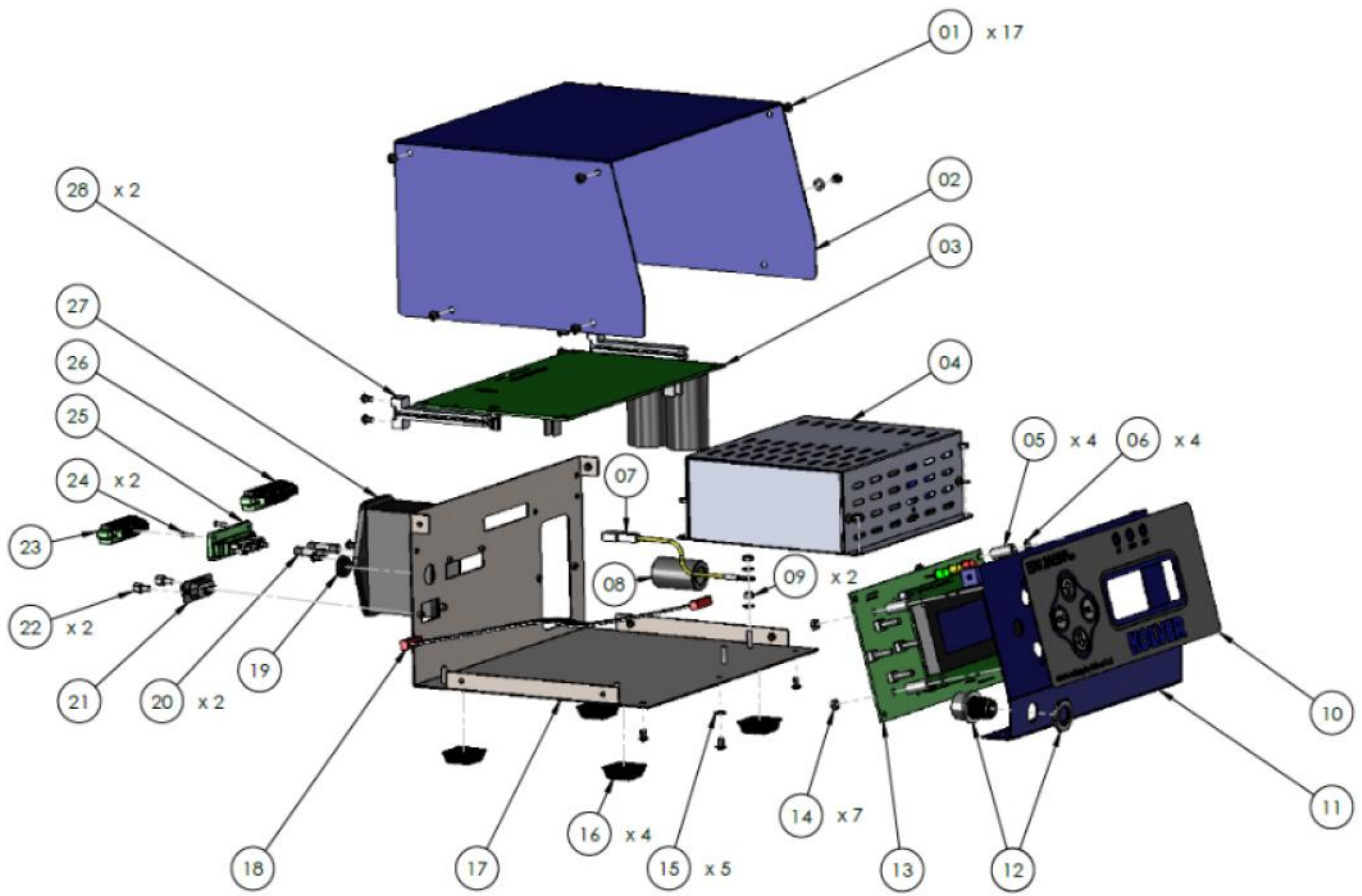

SPARE PARTS

| Position | Description | Quantity | Code |
|-----------------|-------------------------------------|-----------------|-------------|
| 1 | Screw M3x5 TX10 | 17 | 872444 |
| 2 | Upper panel 2AE | 1 | 819003 |
| 3 | Main PCB | 1 | 852521/SW |
| 4 | Switching 48V 600W | 1 | 872490 |
| 5 | Spacer 15mm - 4,8 mm | 4 | 890004/T |
| 6 | Washer M3 h0,5 mm | 4 | 800042 |
| 7 | Ground cable | 1 | 800090/E |
| 8 | Ferrite | 1 | 872468 |
| 9 | M3 Brass nut | 2 | 800056/O |
| 10 | Front membrane EDU 2AE/FR | 1 | 858004 |
| 11 | Front panel EDU2AE | 1 | 818002 |
| 12 | Connector M12 5 pin + nut + ferrite | 1 | 201666/R1 |
| 13 | Display EDU2AE | 1 | 852522 |
| 14 | Zn-white nut M3 | 7 | 800056 |
| 15 | Washer M3 | 5 | 800041 |
| 16 | Plastic support | 4 | 800016/B |
| 17 | Bottom panel EDU2AE/HPro/SW | 1 | 818001/SW |
| 18 | Flat 10 vie | 1 | 872438 |
| 19 | Cap | 1 | 800168 |
| 20 | Fuse 3.15A | 2 | 800619 |
| 21 | F serial connector | 1 | 890005/F |
| 22 | Spacer M3 M-F | 1 | 872453 |
| 23 | F 8 pin connector | 1 | 872464 |
| 24 | Screw M2x6 | 2 | 801004 |
| 25 | M 8 pin connector | 1 | 872457 |
| 26 | Connector I/O 10 pin spacing 3,81 | 1 | 800102 |
| 27 | Filtered plug | 1 | 800718 |
| 28 | Board support | 2 | 872442 |
| | Label | 1 | 818006/SW |

GUARANTEE

1. This KOLVER product is guaranteed against defective workmanship or materials, for a maximum period of 12 months following the date of purchase from KOLVER, provided that its usage is limited to single shift operation throughout that period. If the usage rate exceeds of single shift operation, the guarantee period shall be reduced on a prorata basis.
2. If, during the guarantee period, the product appears to be defective in workmanship or materials, it should be returned to KOLVER or its distributors, transport prepaid, together with a short description of the alleged defect. KOLVER shall, at its sole discretion, arrange to repair or replace free of charge such items.
3. This guarantee does not cover repair or replacement required as a consequence of products which have been abused, misused or modified, or which have been repaired using not original KOLVER spare parts or by not authorized service personnel.
4. KOLVER accepts no claim for labour or other expenditure made upon defective products.
5. Any direct, incidental or consequential damages whatsoever arising from any defect are expressly excluded.
6. This guarantee replaces all other guarantees, or conditions, expressed or implied, regarding the quality, the marketability or the fitness for any particular purpose.
7. No one, whether an agent, servant or employee of KOLVER, is authorized to add to or modify the terms of this limited guarantee in any way. However it's possible to extend the warranty with an extra cost. Further information at kolver@kolver.it.